



# Installation & Operator's Manual

**SEC18**      77-50280W  
18,000 lbs.

# SAFETY WARNINGS



READ INSTRUCTIONS

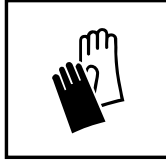

ALWAYS WEAR GLOVES



ALWAYS USE WINCH STRAP

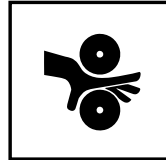

PINCH HAZARD  
KEEP FINGERS AWAY



DO NOT USE WINCH TO  
TRANSPORT PEOPLE



DO NOT USE WINCH TO  
HOIST

1. **LEARN TO USE YOUR MILE MARKER WINCH:** After winch has been installed, take some time and practice using it so you will be familiar with ALL OPERATIONS. Periodically check the winch installation to ensure that all bolts are tight. To ensure proper operation, carefully inspect winch for any damaged parts before operating.
2. **KEEP WINCHING AREA CLEAR:** Do not allow people to remain in the area during winching operations. Do not step over a taut steel cable or allow anyone else to do so. Due to the possibility of steel cable failure, stand clear of any possible pathway. A snapped steel cable could cause winch failure, injury or death. Do not reach over or across winch or steel cable while operating.  
**INSPECT STEEL CABLE AND EQUIPMENT FREQUENTLY:** The steel cable should be inspected for damage that could reduce it's breaking strength.
3. A frayed steel cable with broken strands should be replaced immediately. Always replace the steel cable with a steel cable that is rated to sustain the load that the winch is capable of pulling. Any substitute must be IDENTICAL in strength, quality, lay and stranding to the Mile Marker steel cable originally supplied.
4. **WORKING AREA CONDITIONS:** Keep the working area well lit. Do not use winch in the presence of flammable gases or liquids.
5. **KEEP CHILDREN AWAY:** Keep children away from working area. Never let children operate the winch.
6. **DRESS PROPERLY:** Do not wear loose clothing or jewelry as they can be caught in moving parts. Wear protective, electrically non conductive clothes and non skid footwear when operating the winch. Wear restrictive hair covering to contain long hair.
7. **USE HEAVY GLOVES:** When handling or rewinding steel cable always use hand protection to eliminate the possibility of cuts caused by burrs & slivers from broken strands.
8. **DRUM:** Always make sure that there are at least 5 complete turns of steel cable left on the drum before winching.
9. **KEEP HANDS AND FINGERS CLEAR OF STEEL CABLE AND HOOK WHEN OPERATING WINCH:** Do not put your finger through the hook when reeling in the last few feet. If your finger should become trapped in the hook, you could lose your finger. Do not guide a steel cable under tension onto the drum with your hand.
10. **DO NOT HOOK THE STEEL CABLE BACK ONTO ITSELF:** Hooking the steel cable back onto itself creates an excessive strain that could break individual strands and weaken the entire steel cable.
11. **KEEP PULLING DURATIONS AS SHORT AS POSSIBLE:** The winch is designed for intermittent use and cannot be used in constant duty applications. Do not pull more than one minute at or near rated load. If the motor becomes too hot to touch, stop and let it cool off for a few minutes. If the motor stalls, cut off the power immediately.
12. **DO NOT OVERLOAD:** For your safety and efficient performance, always use this winch at or under its rated capacity. Do not use inappropriate attachments in an attempt to exceed its rated capacity.
13. **AVOID CONTINUOUS PULLS FROM EXTREME ANGLES:** This will cause the steel cable to pile up at one end of the drum. The steel cable should be as straight as possible to the direction of the object.
14. **DO NOT OPERATE THE WINCH WITHOUT THE FAIRLEAD FITTED:** Operator injury or winch damage can result if a fairlead is not installed.
15. **STAY ALERT:** Watch what you are doing. Use your common sense. Do not use this winch when you are tired, stressed or WHEN UNDER THE INFLUENCE OF DRUGS, ALCOHOL OR MEDICATION.
16. **DISCONNECT SWITCH:** Unplug switch when not in use.
17. **REPLACEMENT PARTS & ACCESSORIES:** When servicing, use only identical replacement parts. Usage of any other parts will void the warranty. Approved accessories are available from your local distributor.
18. **DO NOT force clutch.** Rotate drum to align gears for freespool.

# PRECAUTIONS

1. Keeps hands and body away from roller fairlead (steel cable intake slot) when operating.
2. Secure vehicle in position before using winch.
3. Do not exceed winch load weight capacity.
4. Be certain winch is properly bolted to a structure (or vehicle) that can hold the winch load.
5. Always use proper couplings when connecting winch steel cable hook to load.
6. Do not lift items vertically. The winch was designed for horizontal use only.
7. Do not overload the winch. It will do the job better at the load it was intended.
8. Do not use inappropriate attachments to extend the length of the steel cable.
9. Do not lift people or hoist loads over people.
10. Do not come in between the winch and the load when operating.
11. After moving an item with the winch, secure the item. Do not rely on the winch to hold it for an extended period.
12. Examine winch before using. Components may be affected by exposure to everyday weathering, chemicals, salts, and rust.
13. Do not fully extend steel cable while under load. Keep 5 COMPLETE TURNS of steel cable around the winch drum.
14. When loading a boat into a trailer without reel or side hull rollers, make sure the trailer is submerged in the water when the boat is loaded by the winch. Attempting to drag the boat on to the trailer while on land can cause winch failure and possible injury.
15. Do not operate winch if steel cable shows any signs of weakening, is knotted or kinked.
16. Winch does not have a locking mechanism. Secure load after moving.
17. Do not cross over or under the steel cable while it is in process of loading.
18. Do not move vehicle with steel cable extended and attached to load to pull it. The steel cable could snap.
19. Apply blocks (such as a wheel choke) to vehicle when parked on an incline.
20. Respool steel cable properly.

# INSTALLATION

NOTE: Depending on your knowledge of electrical wiring, you may wish to have this winch installed by a qualified technician

1. Select a site to mount your winch mounting frame (not included) and winch
  - CAUTION: Choose a mounting site that will withstand the pulling force of the winch
  - Depending on mounting site, steel reinforcement plates (not included) may be required
  - Depending on mounting site, additional bracing (not included) may be needed and can be welded on before installing winch
2. Make sure winch is on flat surface, and attach the supplied solenoid bracket by removing the two screws from the motor end bearing assembly (Fig. 1).
3. Mount the solenoid assembly and solenoid bracket to the winch
4. After frame and additional plates are setup, mount the roller fairlead to the mounting frame using the supplied bolts and nuts
  - Before mounting fairlead, remove 1 horizontal and 1 vertical roller. They will be re-installed after winch is mounted.
5. Mount the winch to the mounting frame using bolts and nuts (Fig. 2). All eight M12 X 35 bolts must be used for proper installation.

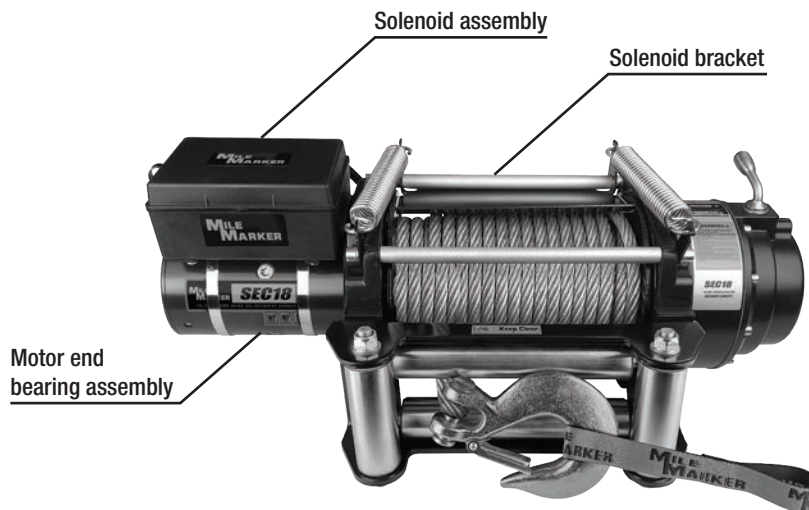

Fig. 1

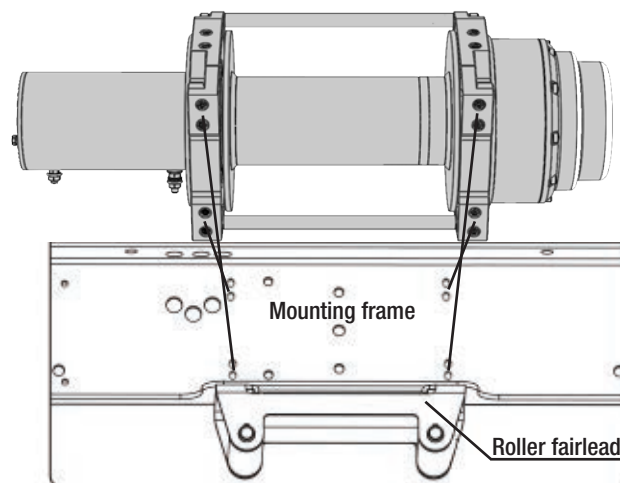

Fig. 2

6. Before wiring, match the color of the motor terminals and power cable
7. Connect the three short cables (red, black, yellow) to the color-coded terminals on the motor
8. Connect the red long cable from the solenoid to the POSITIVE battery terminal and the long black cable to the NEGATIVE battery terminal
9. Connect the other end of both to the motor
10. Connect thin black wire (ground wire) from the solenoid assembly to the motor  
Remove socket cover on the solenoid and inset the plug of the remote control
  - NOTE: After the winch is mounted and powered, check the direction of the power in and power out buttons on the remote. If you wish to switch the direction, disconnect the cable from the battery, switch the yellow cable with the blue, and reconnect the battery cables.
11. Disconnect the remote when not in use

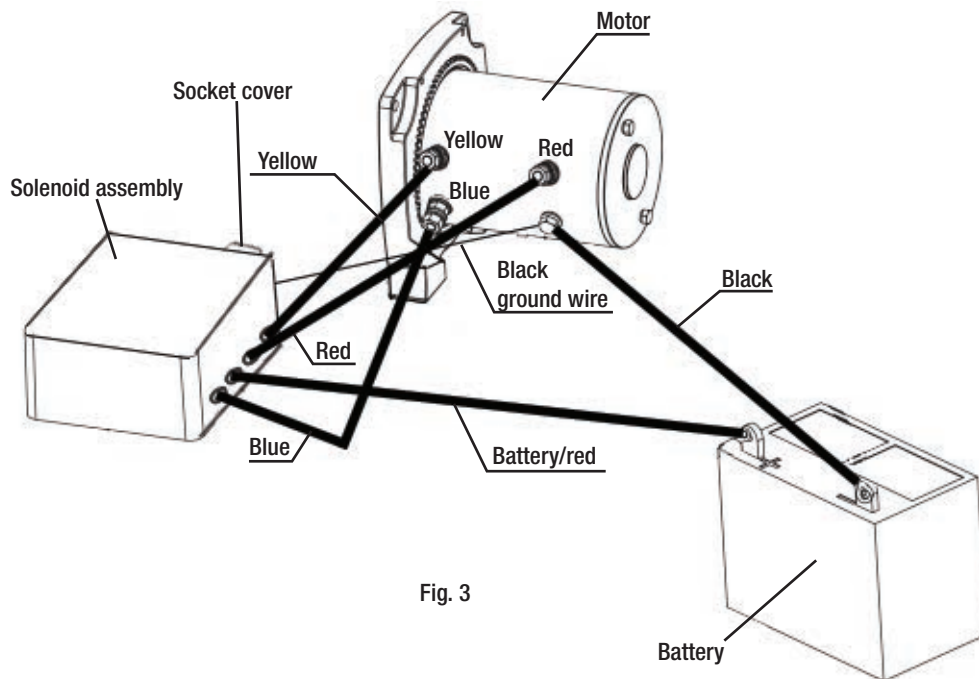

Fig. 3

12. Engage and disengage the clutch by turning the clutch handle (Fig. 4)
13. Pull the cable through the fairlead and connect the hook
  - NOTE: The use of at least a 650 CCA battery is recommended



Fig. 4

# WINCH OPERATION

1. Disengage the clutch by moving the clutch handle to the disengaged position
2. Grab assembly hook with hand strap and pull cable
  - NOTE: Always leave at least 5 turns of cable on the drum. Review safety warnings on page 1.
3. Attach to item being pulled
  - Recommended: Place winch cable dampener over cable
4. Reengage the clutch by moving handle to engaged position
5. Remove socket cover on the solenoid and insert the plug of the remote control (Fig. 5)
6. While standing outside of the tow path, push the button on the remote forward and backward (Fig. 6 and Fig. 7) to check winch running directions. Wait until the motor stops before reversing directions.
  - CAUTION: Do not power winch out for more than 10 seconds at a time. This may cause damage to the brake system.

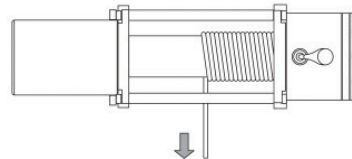
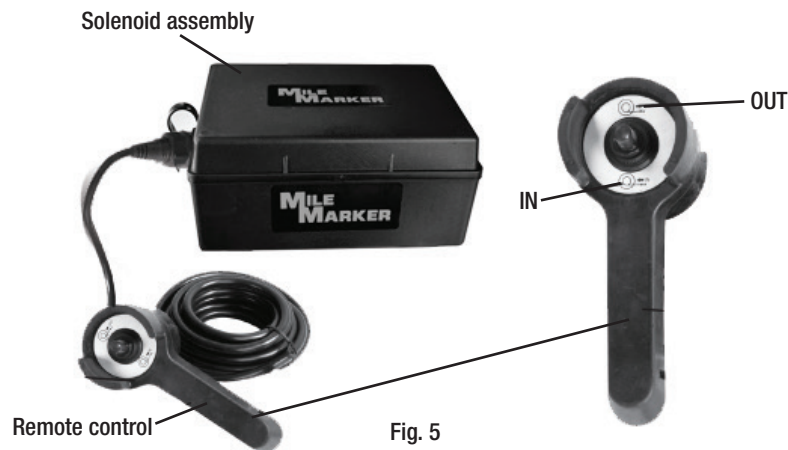

Fig. 6

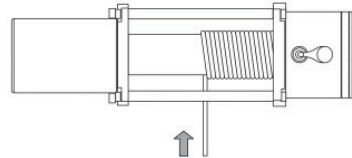

Fig. 7

7. Stand back when pulling. When complete, rewind the cable onto the drum.
  - Cable must be rewound under a load of at least 500 pounds to prevent damage to the cable
8. Remove the remote from the socket and replace socket cover

**CAUTION:** It is important to make sure the winch is mounted on flat surface to guarantee the 3 major sections of the winch (the motor end, the cable drum and the gear housing end) are properly aligned. Run the vehicle engine during pulling operations to keep the battery charging.

# WINCHING TIPS & TECHNIQUES

## Winching Tips and Use of a Snatch Block

- Use tow hooks, recovery eyes or clevis mounts for attachment of a tow strap or winch steel cable.  
NOTE: Do not use a ball and/or ball mount as an anchor point for tow strap or winch steel cable. Severe personal injury or death could occur.
- Always heed all winch manufacturer's recommendations, cautions, and warnings.
- Attach return steel cable to tow hook or recovery eye when using a snatch block. Always use a clevis to secure snatch block to strap, or severe damage could occur to persons and vehicle.  
NOTE: Do not attach return steel cable to winch mount. This may overload winch mount and/or front receiver.

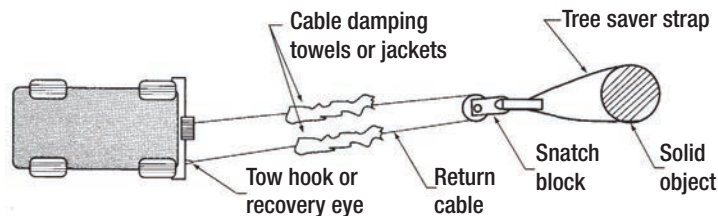

## Rating

For maximum line pull rating, winch cable direction must not exceed:

- 15° angle up or down from horizontal
- 45° angle left or right from straight ahead

Caution: Exceeding the maximum line pull rating may overload winch, mount, and/or front mounted receiver

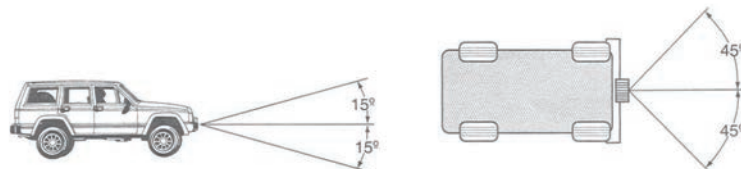

## Safety Tips

- DO NOT DISENGAGE CLUTCH LEVER WHEN THERE IS A LOAD ON THE WINCH.** Mile Marker electric winches utilize an automatic load holding brake, therefore no adjustment to clutch is needed to maintain load.
- Store the remote control cord in a safe place when not in use to prevent use by children or other unauthorized persons who could injure themselves or others or damage the controls.
- Do not operate winch under the influence of drugs, alcohol, or medication.
- Isolate winch before putting hands in or around the roller fairlead or steel cable drum.
- DO NOT OVERLOAD YOUR WINCH.** Do not maintain power to the winch if the drum stops. Overloads can damage the vehicle, winch or winch steel cable and create unstable operating conditions.
- It is recommended to lay a dampener over the steel cable about halfway along to the hook attachment. If a steel cable failure should occur, the weight of the dampener will help prevent the broken steel cable from whipping. Remember to move the dampener as winching proceeds, but halt winching when doing so. Partially raising the hood of the vehicle will also give a measure of protection to its occupants from broken steel cable, consistent with sufficient forward visibility for the operator.

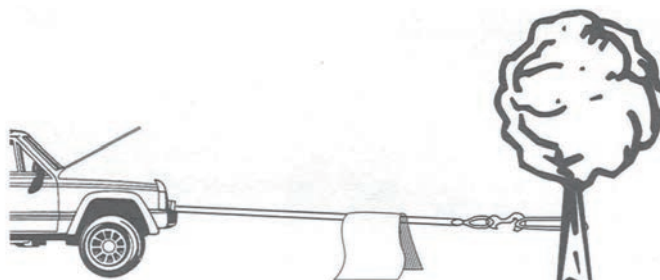

# Self Recovery

1. Always attempt to get the steel cable as straight as possible to the direction of the vehicle. It is acceptable to start a pull at an angle if it is obvious that the vehicle will turn towards the hook anchoring point. Turning the steering wheel will assist the process. It is recommended that the driver is in the vehicle.
2. Make sure hand brake and foot brake are free and that the transmission is in neutral.
3. When the driver's attempt to regain vehicle traction is successful, he or she should be careful not to overrun the cable and risk the possibility of it being trapped under the vehicle.
4. DO NOT move your vehicle in reverse to assist the winch. The combination of the winch and vehicle pulling together could overload the cable and winch itself.
5. DO NOT connect steel cable or hook back to winch mount.

# Use of a Pulley Block or Snatch Block

**Vehicle self recovery using the pulley block attached to the anchor point for direct pull.** In this instance the vehicle becomes the "load" and the actual pulling power on the vehicle will be double at half winch steel cable speed. Do not connect steel cable or hook back to winch mount.

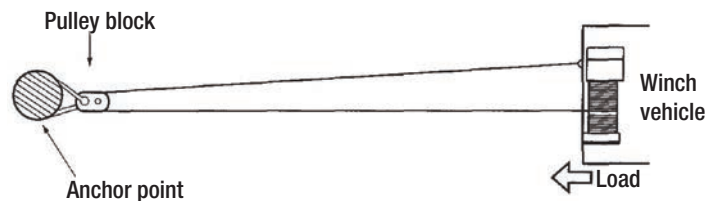

**Direct pull on load using the winch vehicles as the anchor with pulley block attached to the load.** The most important aid to successful winching is the pulley block, which can be used to increase the pulling power of the winch or for indirect pulls. Pulley blocks can be used in two modes. First mode is attached to the load and second is secured to an anchor point.

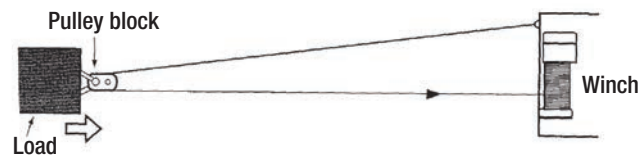

**Indirect pull necessitated by obstructions or soft ground.** Attach pulley block to load using a suitable anchor point. NOTE: The angled direction taken by the load and subsequent angle of steel cable feed back on the winch drum (extreme example shown). There may be unavoidable circumstances requiring this mode, though in general it is not recommended unless applied in stages by moving the anchor point or vehicle to avoid the sharp angled rewind on the winch drum. The actual load pulling power and steel cable speed will depreciate with any increased angle between the steel cables. The anchor point, when used must be secure, using a tree, another vehicle or any firm structure to which a pulley block can be used to your advantage.

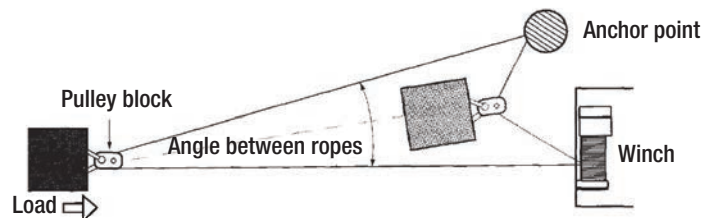

# Use of a Nylon Sling and Shackle

A shackle should always be used when attaching winch hooks to nylon slings. NOTE: The shackle must pass through both eyes of the sling. The safe working load of the nylon sling is based on the use of both eye ends. Do not use the cable or hook to connect directly to the nylon sling.



## Use of Gloves

When handling or rewinding the steel cable always use gloves to reduce the possibility of cuts that can be caused by burrs or broken strands. Inspect cable and equipment frequently. The cable should be replaced immediately if there are any evident signs of fraying, burrs, or broken strands. Replace the cable with a Mile Marker recommended replacement part and make sure the cable is rated to sustain any load the winch is capable of pulling. Substitutes must be identical in strength, quality, lay and stranding to the Mile Marker steel cable originally provided. Do not hook the cable back onto itself. Hooking the cable back onto itself creates an unacceptable strain, breaking individual strands, which in turn weakens the entire cable. Use a sling and avoid continuous pulls from extreme angles as this causes cable to pile up at one end of the drum.

## Motor Temperature

ELECTRIC WINCHES ARE DESIGNED FOR INTERMITTENT USE ONLY. Do not run this winch at a high load for an extended period of time. To check the motor temperature: stop operation, secure the load, release the tension on the steel cable, and place your hand on the motor to check temperature. If you feel the motor is warm to the touch, let it cool off for a few minutes. If the motor is laboring, stop sooner and more often to check the motor temperature. Using a double line with a snatch block will reduce the load on the winch to about half. The lower the amp load on the winch, the longer it will take to heat up the motor.

## Spooling Under Load

Spooling Under Load: Always ensure that steel cable passes between drum and mounting surface. Always wind the steel cable as evenly and tightly as possible. Avoid shock loading the winch when spooling in. If this is done you can cause a hazardous condition that can break the steel cable or damage the winch. Avoid pulling at an angle for an extended period. This will stack the steel cable up on side of the spool and cause serious damage to the winch. You may have to reposition the cable a few times to allow the winch to pull in a straight line.

## Rigging

Spool out as much cable as possible to the farthest object available. Keep the cable in as straight a line as you can. Spool the line back on the winch as evenly as possible when retrieving the cable. Natural anchors like trees, stumps and rocks are the better choices. Always use a tree saver strap wherever possible. Only connect the steel cable to an object that will be able to resist the pulling power of the winch being used.

# WINCH MAINTENANCE

- All moving parts within the electric winch have been lubricated using high temperature lithium grease at the factory. No further internal lubrication is required for the life of the winch.
- If using steel cable, lubricate the steel cable periodically using light penetrating oil.
- Electrical connections may corrode over a period of time due to environmental changes. This may result in reduced performance of the winch or even possible electrical shorting. Hence, always clean the electrical connections before and after using the winch.
- After every use of the winch, inspect the steel cable for damages such as kinks, broken strands etc. When damaged, replace the cable immediately.

# TROUBLESHOOTING

Symptom	Possible Cause	Suggested Remedy
Motor does not turn on	Safety switch is OFF	Turn safety switch ON
	Switch assembly not connected properly	Insert switch assembly firmly to the connector
	Loose battery cable	Tighten nuts on cable connectors
	- Connection - Solenoid malfunctioning	Tap solenoid to free contact, applying 12 volts to coil terminal directly. An audible clicking will occur when activating.
	Defective switch assembly	Replace switch assembly
	Defective motor	Check for voltage at armature port with switch pressed. If voltage is present, replace motor.
	Water has entered motor	Drain and dry. Run in short bursts without load until completely dry.
Motor runs too hot	Long period of operation	Let winch cool down periodically
Motor runs slowly or without normal power	Battery runs down	Recharge battery by running vehicle engine
	Insufficient current or voltage	Clean, tighten or replace the connector
Motor runs but cable drum does not turn	Clutch not engaged	Turn clutch gear to IN/ENGAGED position - if that does not work, ask a qualified technician to check and repair
Motor runs in one direction only	Defective or stuck solenoid	Tap solenoid to free contacts. Repair or replace solenoid.
	Defective switch assembly	Replace switch assembly

# PARTS BREAKDOWN & ASSEMBLY

ITEM	QTY	PART#	DESCRIPTION
1	1	77-502080W-01	Solenoid Assembly
2	2	77-502080W-02	Solenoid Bracket
3	2	77-502080W-03	Hose Clamps
4	4	77-502080W-04	Washer 6
5	4	77-502080W-05	Spring Washer
6	4	77-502080W-06	Screw M6 x 16
7	6	77-502080W-07	Screw M10 x 30
8	6	77-502080W-08	Spring Washer 10
9	1	77-502080W-09	Switch Assembly
10	2	77-502080W-10	Tie Bar
11	1	77-502080W-11	Roller Farilead
12	1	77-502080W-12	Tension Plate
13	2	77-502080W-13	Spring
14	2	77-502080W-14	Hooking Bracket
15	2	77-502080W-15	Screw M10 x 12
16	1	77-502080W-16	Drum Assembly
17	1	77-502080W-17	Screw M8 x 10
18	1	77-502080W-18	Brake Fittings
19	2	77-502080W-19	X Ring
20	2	77-502080W-20	Seal
21	1	77-502080W-21	Brake/Shaft Assembly
22	2	77-502080W-22	Gasket
23	1	77-502080W-23	Motor End
24	1	77-502080W-24	Gear Input sun

ITEM	QTY	PART#	DESCRIPTION
25	1	77-502080W-25	Screw
26	1	77-502080W-26	Pin
27	1	77-502080W-27	Locating Pin
28	1	77-502080W-28	Spring
29	1	77-502080W-29	Clutch Handle
30	1	77-502080W-30	O Seal Ring
31	1	77-502080W-31	Seal Ring Cover
32	1	77-502080W-32	Ring
33	10	77-502080W-33	Screw M6 x 60
34	10	77-502080W-34	Spring Washer 6
35	1	77-502080W-35	Gear Box Cover
36	1	77-502080W-36	Gear Ring
37	1	77-502080W-37	Gear Ring
38	1	77-502080W-38	Bearing
39	1	77-502080W-39	Spacer
40	1	77-502080W-40	Retaining Ring
41	1	77-502080W-41	Safety Hook
42	1	77-502080W-42	Gear Carrier Assembly Input
43	1	77-502080W-43	Gear Carrier Assembly Intermediate
44	2	77-502080W-44	Gasket
45	1	77-502080W-45	Gear Carrier Assembly Output
46	1	77-502080W-46	Gear Ring
47	1	77-502080W-47	End Bearing
48	1	77-502080W-48	Cable
49	1	77-502080W-49	Hand Strap

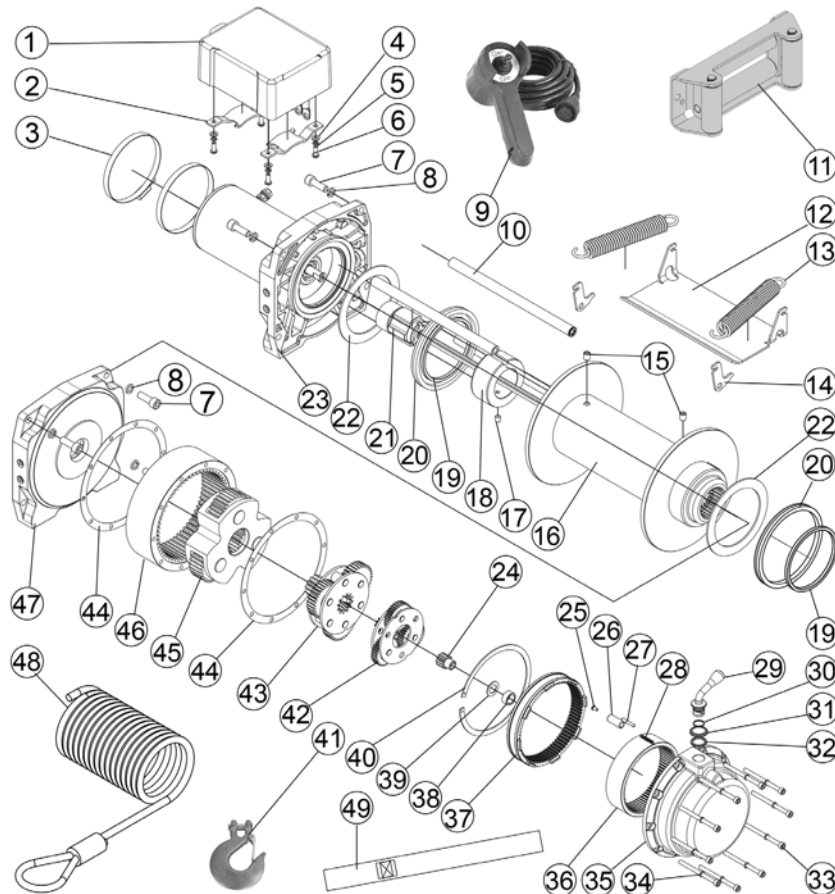

# WARRANTY

## Mile Marker/Selectro Hubs and Conversion Kits Limited Warranty

Mile Marker Industries warrants directly to the first purchaser that part numbers 427, 428, and all “Selectro Classic” models will be free from defect in material and workmanship appearing under normal use and service for a period of one year.

Mile Marker Industries warrants directly to the first purchaser that part numbers 426 and 460 will be free from defect in material and workmanship appearing under normal use and service for a period of two years.

Mile Marker Industries warrants directly to the first purchaser that part numbers 104, 302, 423, 430, 435, 436, 449SS, 457, 459SS, 466, 470, 481, 490 and 549 will be free from defect in material and workmanship appearing under normal use and service for as long as said purchaser owns the Premium Locking Hubs.

Mile Marker Industries warrants directly to the first purchaser that all Mile Marker Conversion Kits will be free from defect in material and workmanship appearing under normal use and service for a period of one year.

Warranty registration must be submitted at [milemarker.com/warranty](http://milemarker.com/warranty) within thirty days of purchase by the end user. If you discover a hidden defect, Mile Marker will, as its option, repair or replace the product or necessary replacement parts at no charge to you, provided you remove the product from the vehicle and return it prepaid to Mile Marker Industries. If the product was purchased in the United States, the owner must contact our warranty department to get a Return Goods Authorization (RGA) number before returning the product. If the product was purchased outside the United States, the owner must return the product to the original place of purchase.

## Mile Marker Industries Hydraulic Winch Limited Warranty

Mile Marker Industries warrants each winch when used in normal service against factory defects in materials and workmanship to the original commercial and recreational purchaser for the period of five years. New cable assemblies are warranted against defects in workmanship and materials when received by the retail purchaser. There is no applicable warranty for cable assemblies after initial use. Excluded from this warranty are the finish of the winch and any condition Mile Marker determines to have been caused by misuse or abnormal use. Warranty registration must be submitted at [milemarker.com/warranty](http://milemarker.com/warranty) within thirty days by the end user. Warranty submissions must reference winch serial number to be valid. Warranty will only be valid for the original purchaser of the winch and installed on the vehicle for which it was originally registered. The owner will be responsible for removing the winch and returning it to Mile Marker freight prepaid unless a determination is made that replacement parts can be sent out which will remedy the problem. Mile Marker will repair or replace any or all winch parts, which after inspection determines to be defective. If the product was purchased in the United States, the owner must contact our warranty department to get a Return Goods Authorization (RGA) number before returning the product. If the product was purchased outside the United States, the owner must return the product to the original place of purchase.

## Mile Marker Industries Electric Winch Limited Two Year Warranty

Mile Marker, Industries offers a limited two year warranty to the original retail purchaser for each new Mile Marker electric winch, used as a recreational recovery winch only, against manufacturing defects in workmanship and materials on all mechanical components. Electrical components consisting of motors, solenoids, wiring, wire connectors and associated parts have a limited one year warranty. New cable assemblies are warranted against defects in workmanship and materials when received by the retail purchaser. There is no applicable warranty for cable assemblies after initial use. Excluded from this warranty are the finish of the winch and any condition Mile Marker determines to have been caused by misuse or abnormal use. Warranty registration must be submitted at [milemarker.com/warranty](http://milemarker.com/warranty) within thirty days by the end user. Warranty submissions must reference winch serial number to be valid. Warranty will only be valid for the original purchaser of the winch and installed on the vehicle for which it was originally registered. The owner will be responsible for removing the winch and returning it to Mile Marker freight prepaid unless a determination is made that replacement parts can be sent out which will remedy the problem. Mile Marker will repair or replace any or all winch parts, which after inspection determines to be defective. If the product was purchased in the United States, the owner must contact our warranty department to get a Return Goods Authorization (RGA) number before returning the product. If the product was purchased outside the United States, the owner must return the product to the original place of purchase.

For full warranty and general warranty procedure and policy visit [milemarker.com/warranty](http://milemarker.com/warranty)